

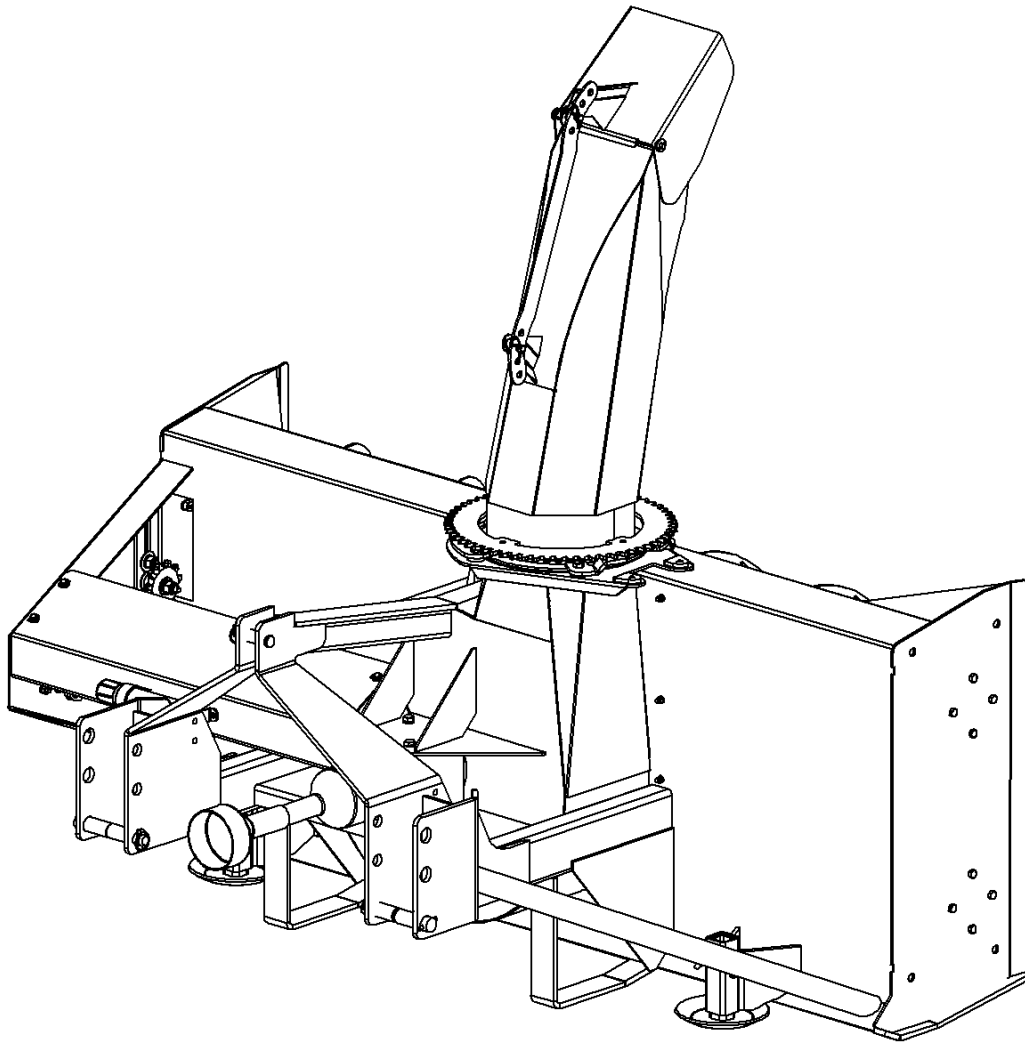

## 97D-108D Meteor Snowblower Operator's / Parts Manual



MK Martin Enterprise Inc.  
3950 Steffler Rd Elmira, ON, Canada N3B 2Z3

Tel: 519-664-2752  
Toll Free: 1-855-664-2752  
Fax: 519-664-3695  
E-mail: [sales@mkmartin.ca](mailto:sales@mkmartin.ca)  
[www.mkmartin.ca](http://www.mkmartin.ca)



REV: 15-1

**Intensionally Blank**

## Table of Content

• Registration	4
• Warranty	5
• Safety	7-9
• Decal Location	10
• Sign-Off Sheet	11
• Operation	12-13
• Assembly	14
• Chute Rotator Installation	15-17
• Parts	18-19
• Chute Stop	20
• Chute Rotator Parts	21
• T 80 PTO Parts	22-23
• T90 PTO Parts	24-25
• 1000 RPM Gearbox Parts	26-27
• 1000 RPM Kit	28
• 1000 RPM PTO Parts	29-30
• Gearbox	31
• PTO Instructions	32-39
• Bolt Torque	40
• Maintenance	41

## Warranty and Limitations of Liability

All equipment is sold subject to mutual agreement that it is warranted at M K Martin Inc. (Hereafter called the company) to be free of any defects of material and workmanship. The company shall not be liable for special, indirect or consequential damage of any kind under this contract or otherwise. The company's liability shall be limited exclusively to replacement or repair without charge at it's factory or elsewhere, at it's discretion, any materials or defects, which become apparent within one year from the date of purchase. In no event shall M K Martin Enterprise Inc. be liable for special, direct or incidental or consequential damages of any kind. The purchaser by acceptance of the equipment will assume all liability for damage which may result from use or misuse by the operator. The purchaser shall maintain and service the equipment as recommended in the Operator's Manual.

This warranty does not cover **Rental/Commercial or Rental** use of the equipment. This equipment is rated as agricultural.

For **Rental/Commercial or Industrial** use, Warranty is for defective material and workmanship for a period of 90 days from the date of purchase.

Warranty is null and void unless the Warranty Registration form has been completed and on file at

M K Martin Enterprise Inc  
3950 Steffler Rd  
Elmira On Ca N3B 2Z3

For your Record

**Purchase Date** \_\_\_\_\_

**Model #** \_\_\_\_\_

**Serial #** \_\_\_\_\_

Please contact your retailer

**Manufactured by**  
**M K Martin Enterprise Inc**  
**3950 Steffler Rd**  
**Elmira On Ca N3B 2Z3**  
Tel: (519)-664-2752  
(855)-664-2752  
Fax: (519)-664-3695  
E-mail: sales@mkmartin.ca

www.mkmartin.ca

**M K Martin Enterprise Inc**  
**3950 Steffler Rd**  
**Elmira ON CA N3B 2Z3**

*Purchaser's warranty protection is valid only when this completed form or a copy of this form is on file at M K Martin Enterprise Inc. By filling out this form the purchaser has acknowledged delivery of equipment and owner's / operator's manual and has accepted the condition of the equipment.*

**Date of delivery to purchaser** -----

**Type of Equipment** -----

**Model #** ----- **Serial #** -----

**Retailer's Signature Indicates**

- *Equipment was properly assembled as directed by manufacturer*
- *Equipment was tested for functionality and operates properly*
- *Purchaser was instructed in safe and proper operating procedures*
- *Warranty was explained to purchaser*
- *Purchaser was given the operators manual*

***Retailer***

**Signature** -----

**Company** -----

**Address** -----

-----  
**Purchaser's signature indicates**

- *Acceptance of equipment fully assembled*
- *Received operator's manual*
- *Clearly understands conditions of warranty*
- *Received instructions of safe and proper operation of equipment*

***Purchaser***

**Signature** -----

**Company** -----

**Mailing address** -----

**City** ----- **Prov/State** ----- **Postal Code/Zip** -----

**Available phone number** -----

**Warranty is valid only when it has been received by manufacturer at address above**

**Warranty Registration**

**Please Cut and Return to M K Martin Enterprise Inc**

**Fold And Tape here      *Do not tape all edges or use staples***

***Fold Here***

**Postage  
Stamp**

**M K Martin Enterprise Inc  
3950 Steffler Rd  
Elmira ON CA N3B 2Z3**

## Safety

**Take Note!** This safety symbol is found throughout this manual to call your attention to instructions involving yourself and others working around the machine.

- **Failure to follow these instructions can result in injury or death!**



This symbol means

- **Attention!**
- **Become Alert!**
- **Your Safety is involved!**

Signal words are used in this manual.

**Caution:** Indicates a potential hazardous situation that may result in injury.

**Warning:** Indicates a hazardous situation that could result in serious injury or death.

**Danger:** Indicates a hazardous situation that needs to be avoided. It is you the operator that needs to be aware of these dangers.

If you have any questions not answered in this manual please contact you dealer or

M K Martin Enterprise Inc  
3950 Steffler Rd  
Elmira On Ca N3B 2Z3

Tel: 519-664-2752  
1-855-664-2752  
Fax: 519-664-3695  
e-mail sales@mkmartin.ca

[www.mkmartin.ca](http://www.mkmartin.ca)



**Safety -- It's in your interest.**



## **Safety Guidelines**

Safety of operation is one of our main concerns, however it is up to the operator to practice caution.

To avoid personal injury, study the following precautions and insist that those working with you follow them.

The Meteor Snowblower has only 2 shields, one shield is the PTO drive shield and the other is a shield for the power hood turner if used. **Do not use the blower with the auger drive cover removed as this is part of the blower frame.**

Replace any decals that may be missing or not readable. Location of decals are indicated elsewhere in this manual.

Do not use this machine while under the influence of drugs or alcohol.

Review the safety instructions with all users annually.

This equipment should not be operated by those unfamiliar with the operation of the Meteor Blower. **Do not allow persons to operate this machine until they have read this manual and/or were instructed by a qualified person,**

Do not use this machine to push snow as this can result in the auger being broken or bent.



Please be careful with the extra weight on the back to the tractor. It may be necessary to add weights on the front of the tractor to keep it balanced properly.



When changing shearbolts or removing ice or snow from the machine **Please stop the engine and remove the key on the tractor!** This will reduce the possibility of the blower being started and causing personal injury.



## Hydraulic Leak Test



**Warning!** Do not check for high pressure leaks with your hands or fingers. Use a piece of cardboard or a thin piece of wood to detect the leak.

A high pressure stream of fluid from a pin hole can penetrate the skin and inject hydraulic fluid into your blood veins.

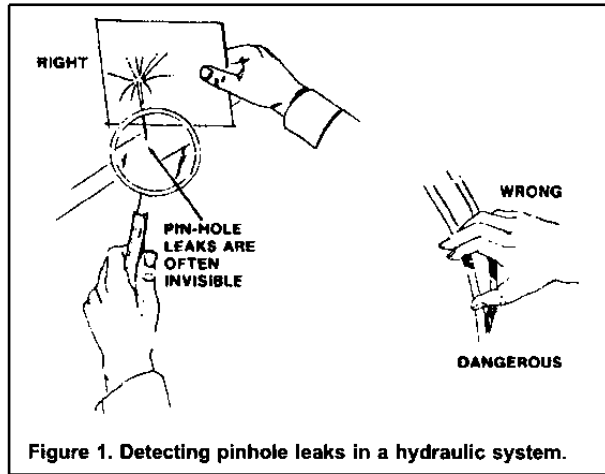

**If the skin has been penetrated get medical attention immediately!**



Hydraulic lines may have high pressure fluid in the lines, even when the lines are disconnected.

Remember a small leak at high pressure may be invisible yet can penetrate the skin. If this happens get medical attention immediately, serious infection or toxic reaction can develop when hydraulic fluid pierces the skin.

Use caution when working with hydraulic components. Ensure there are no leaks, all fittings are tight and all components are in good repair.



Use a piece of wood or cardboard as a backstop when searching for leaks, **NEVER** your hand or fingers.



Always relieve pressure before disconnecting or working on hydraulic system.

## Meteor Snowblower Decal Location

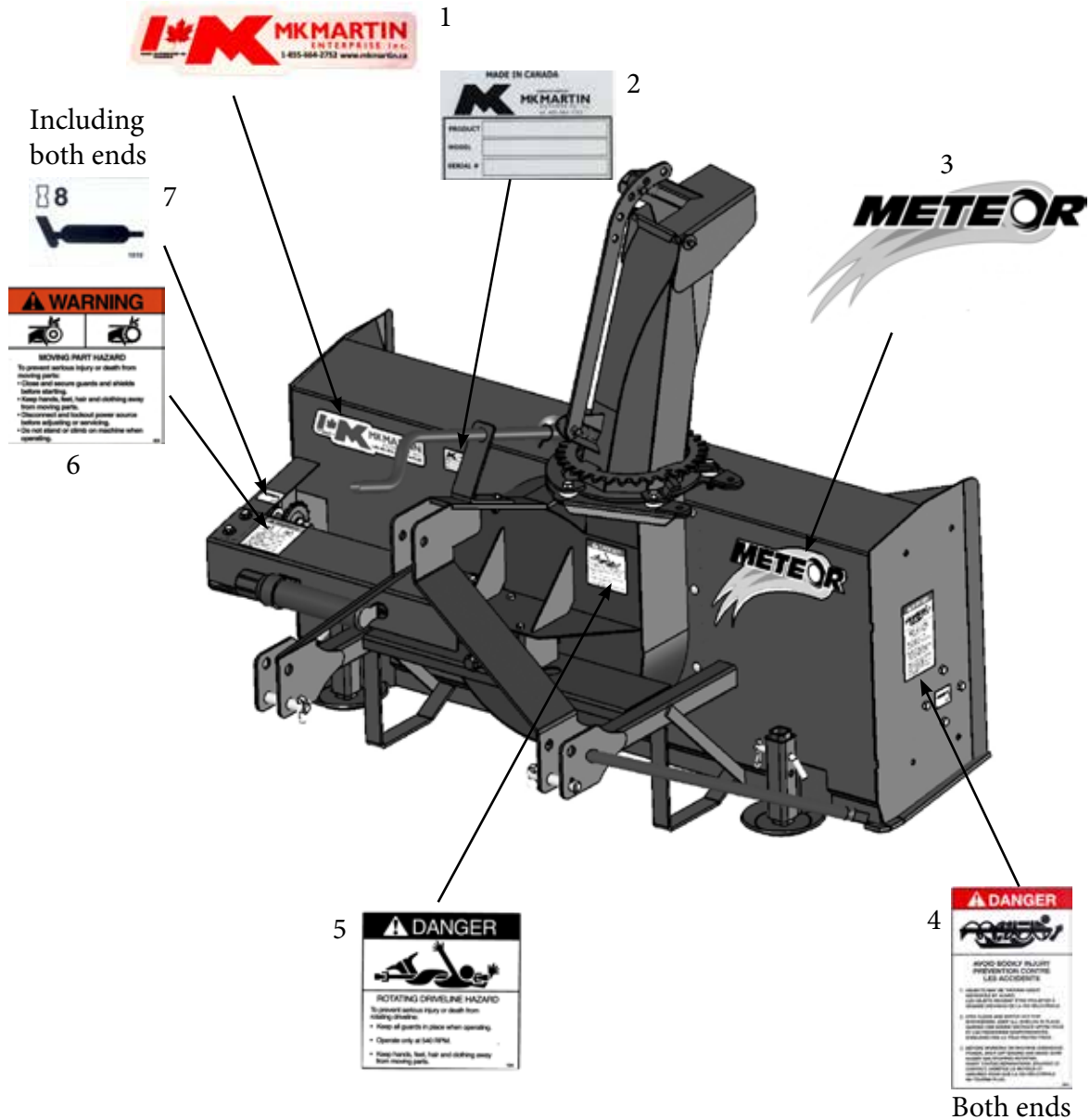

Item #	Part #	Description	Qty
1	decalMKlogomadeincanada	M K Martin Logo	1
2	No Replacement	Serial Plate	1
3	decalmeteorlarge2012	Meteor Logo	1
4	101	Danger Decal	2
5	104	Danger Decal	2
6	404	Warning	1
7	decal1010	Grease	3



## 97D - 108 Meteor® Snowblower

This Blower is ideal for tractors 100 - 120 HP Cat #2 3PH.

### Attaching the Meteor® Blower for the first time.

Set the blower on a level surface and back the tractor up to it. Place the lower 3PH arms of the tractor between the lower hitch plates on the blower and insert the hitch pins that came with the blower, secure these with the Lynch Pins. Next swing the top link into place and adjust the length so the top link pin can be inserted. You will have to supply the top link pin. With the top link set at this length the blower will be flat or parallel to the ground.

Do not fasten the PTO shaft to the tractor.

1. Slowly lift the blower until the gearbox shaft is at the same height as the PTO output on the tractor.
2. Push (or collapse the telescopic part of the PTO completely). If you cannot collapse it far enough to slide get it on the tractor then it has to be shortened.
3. Measure the amount that the shaft is too long. Remove it from the blower and pull it apart.
4. Take a hacksaw and cut the full length from each PTO half, **cut both the plastic tube and the metal core.**
5. Use a file to remove the burrs from the cut parts, wipe any filings from the surfaces and slide the shaft together to be sure that it slides freely.
6. Make sure the plastic shield is free to rotate on the shaft before installing on the machine.
7. Reinstall the PTO on the blower and fasten it to the tractor pushing the spring-loaded pin in and sliding the yoke onto the tractor spline until the pin snaps into place.
8. Next lift the 3PH arms to the highest point, determine the overlap on the PTO shaft. It should be at least 3" if it is too short then the PTO will jam rather than collapse. This will put severe strain on the shaft and gearbox.
9.  It may come apart and this will allow a spinning PTO to become an uncontrolled weapon and could **severely injure or kill** someone!
10. After it has been determined that the PTO is OK and will not jam or come apart, make sure any bystanders are well away from the machine.
11. Lower the blower to ground level, engage the PTO and slowly start the blower. Make sure that everything is turning freely.
12. Slowly increase the speed until you have reached 540 RPM on the PTO or (1000 RPM with the 1000 RPM PTO option). This is the speed that this blower was designed for. If it turns faster the fan could be going dangerously fast. If it turns slower it will not perform very well as the snow will not get blown very far.

**Snowblower performance will vary greatly due to ambient temperature and type of snow.**

## Operating the Meteor® Snowblower

This blower is on the back of the tractor facing toward the rear. While blowing snow the tractor has to be backed into the snow.



Stay in the seat of the tractor all the time that the blower is running.



Make sure the area is clear of people while blowing snow.



Do not direct discharged snow toward people, cars or buildings as stones or bits of ice can go a long distance.

When you get to the place that you want to clear snow, lower the blower to the ground and turn the chute to discharge the snow in the direction you want the snow to go. Engage the PTO and slowly bring the blower up to operating speed. After the blower is running use reverse gear and start backing up. The chute can be rotated from the tractor seat while blowing snow.

If your drive is paved then you may need to lengthen the top 3PH link to tilt the blower ahead so it will scrape the hard surface better.

If your drive is gravel then you may want to shorten the top 3PH link to tilt the blower back so it will not dig into the loose gravel. In colder climates where the bare ground is frozen during most of the winter the blower can be adjusted to scrape the snow off the frozen drive after freeze-up.

In areas where the gravel is not frozen most of the time we have skid shoes available to bolt on the end plates to raise the blower a few inches above the gravel.



This blower is designed to blow snow, but will blow loose gravel if care is not taken.



After the job is finished: **Disengage the PTO to stop the blower** before driving away or getting off the tractor.

The auger is protected with a safety shear bolt that will shear off if the auger becomes jammed. The fan is also protected with a shear bolt in the PTO shaft universal joint if the fan becomes jammed.



**When replacing the shear bolts STOP the engine before attempting to replace them!**

The hydraulic hood turner couples into the tractor hydraulic remotes. This will allow you to rotate the hood without reaching back to the blower especially if you have a cab on your tractor.

## 75-108 Meteor Snowblower Assembly Instructions

### Parts for Assembly

- 2 pc Hood Bearing
- 4 pc 5/8" Wavewasher (*thin*)
- 2 pc 5/8x2 UNF bolts
- 2 pc 5/8"UNF Locknut
- 1 pc 2 Hole Chute Clamp
- 1 page Assembly Instructions

### Upon Receiving the Meteor Snowblower

The blowers are shipped in a packaged state

#### These Snowblowers are shipped without hood turner device

Carefully remove the chute and PTO shaft from the area of the snowblower auger and set them aside. Locate the bag or package of small components.

Remove the ties that hold the Plastic Ring on the blower and place base of the chute on top of the plastic ring. (Note: Plastic Ring can be lightly coated with grease at this time).

Take two 5/8 bolts and drop them through the holes in the chute clamp, turn the clamp upside down while holding the bolts in the holes. Place a 5/8 Wavewasher on the bolt, then a 5/8 Bearing, finish with another 5/8 Wavewasher. Turn the clamp rightside up with the washers and bearings on the bolts. Carefully insert the bolts into the chute base and secure with the lock-nuts.

Install the PTO with the shearbolt yoke at the gearbox. *This will provide you with more space when changing shearbolts.*

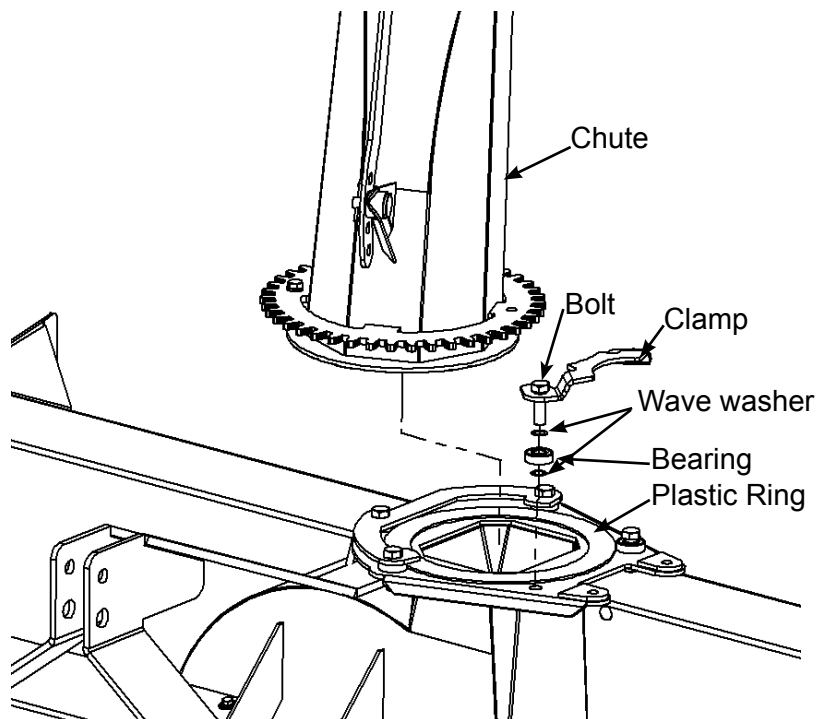

## Motor Hydraulic Rotator Installation

The Hydraulic Chute Rotator uses a hydraulic motor, controlled by the tractor hydraulics to rotate the chute. The kit includes a safety shield, 2 pc 1/2-20 UNF bolts, hydraulic fittings, hoses and tractor couplings. When installing the hydraulic elbows, turn them in “**no more than 4 rounds**” then tighten the jam-nut to secure the elbow in the direction that you want the hoses to go *as shown*.

The relief valves are factory preset at 900 PSI.

Route the hoses and tie them to the top “A” frame support, away from moving parts, Ensure that the hoses do not get too tight or rub on the frame when the blower is raised or lowered.

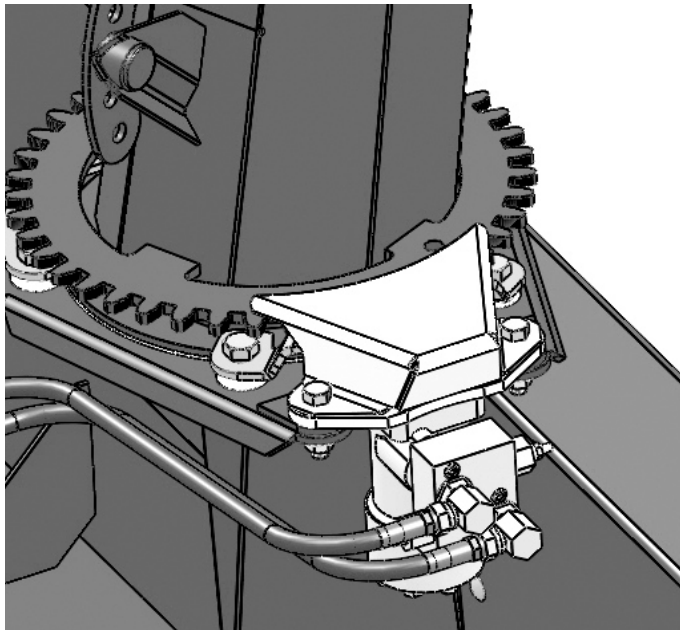

First set the motor with the bracket on top of the Chute Plate and then place the shield on top of the motor bracket and secure with 1/2-20 UNF bolts

Please ensure that the gear does not jam or bind during the rotation of the chute. The bolt holes are slightly oversize, allowing you to adjust the clearance somewhat. You should be able to move the chute back and forth slightly.

## Meteor Snowblower

### Installing Hydraulic Chute Rotator Safety Shield with Hose Guide

The Meteor Hydraulic Chute Rotator has rods that act as guides to guide the Deflector Hydraulic Hose (if used) to the outside of the shield.

All Shields are manufactured with the Rods straight.

They may need to be bent in or out for smaller or larger blowers.

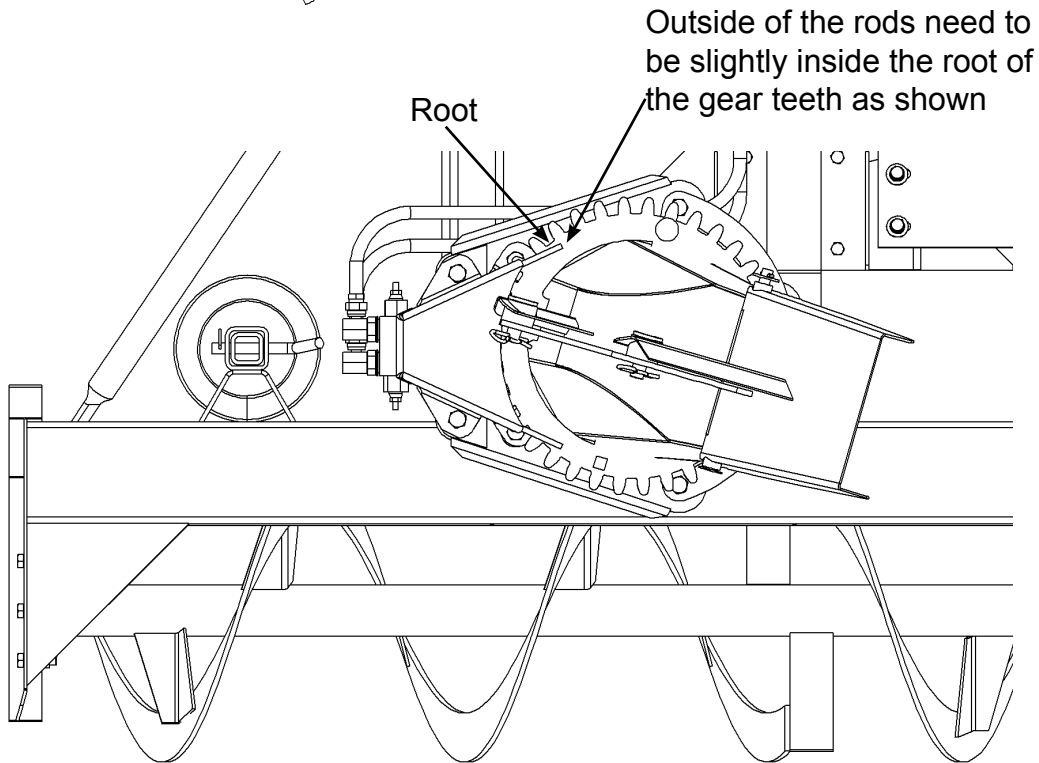
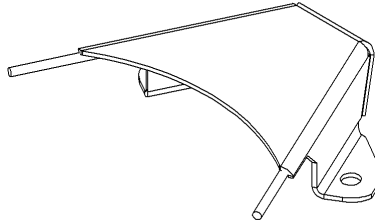
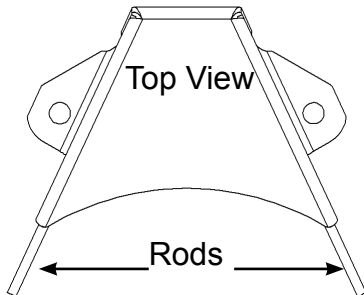

To bend the rod, you can use a short piece of 3/8 pipe for a lever, or an adjustable wrench to bend the rod.

Do not use a hammer as it has less control of the bend.

Keep the height of the rod the same, only bend it in or out.

After installation carefully rotate the chute to ensure that there is no interference or binding.



For Smaller blowers rods are bent in  
as shown

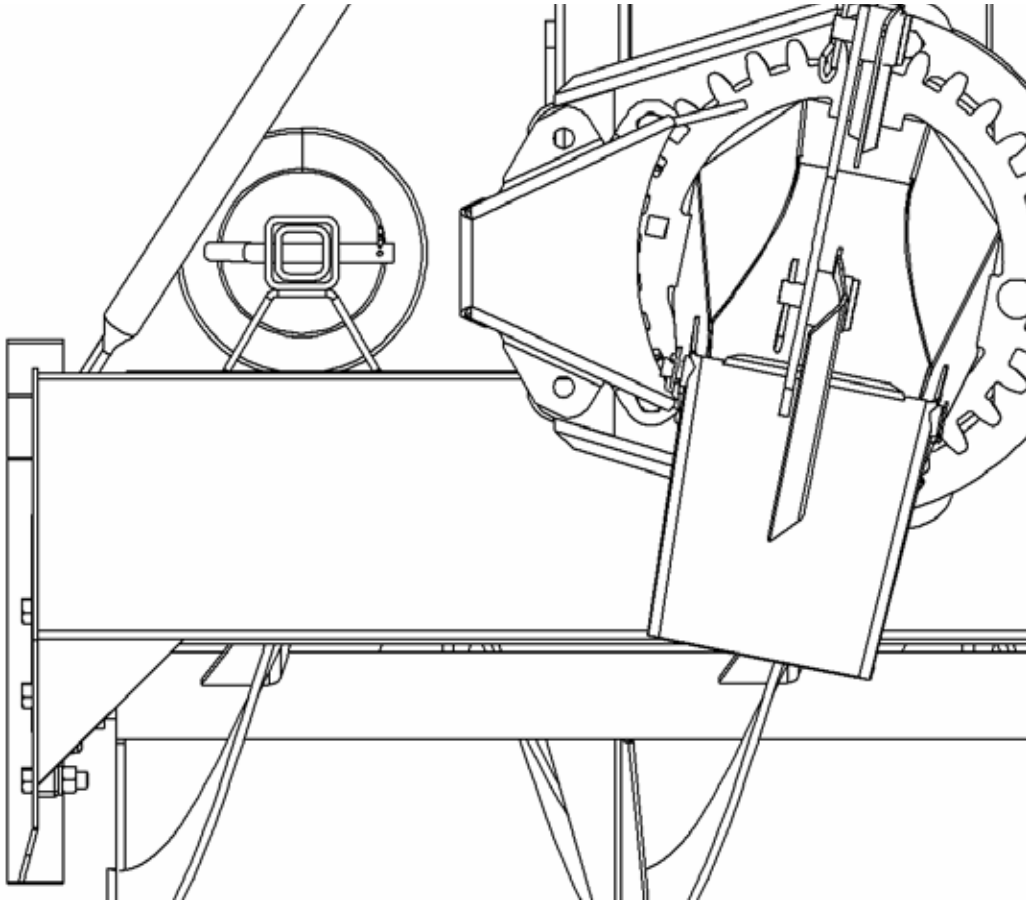

For Larger Blowers rods are Bent out  
as shown

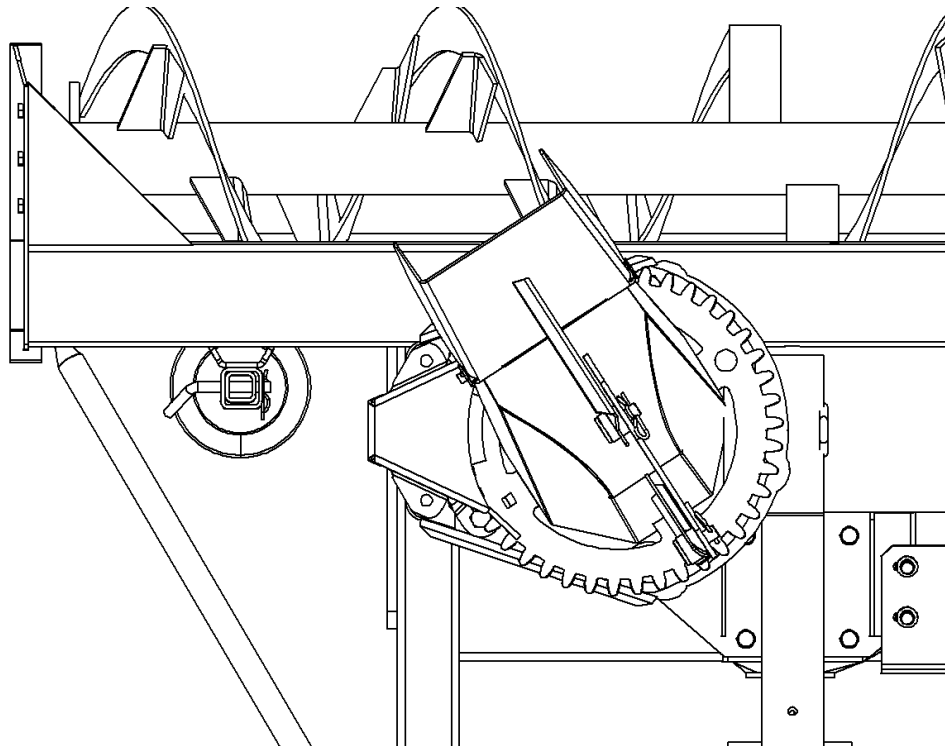

## 97D - 108 Meteor Snowblower Parts

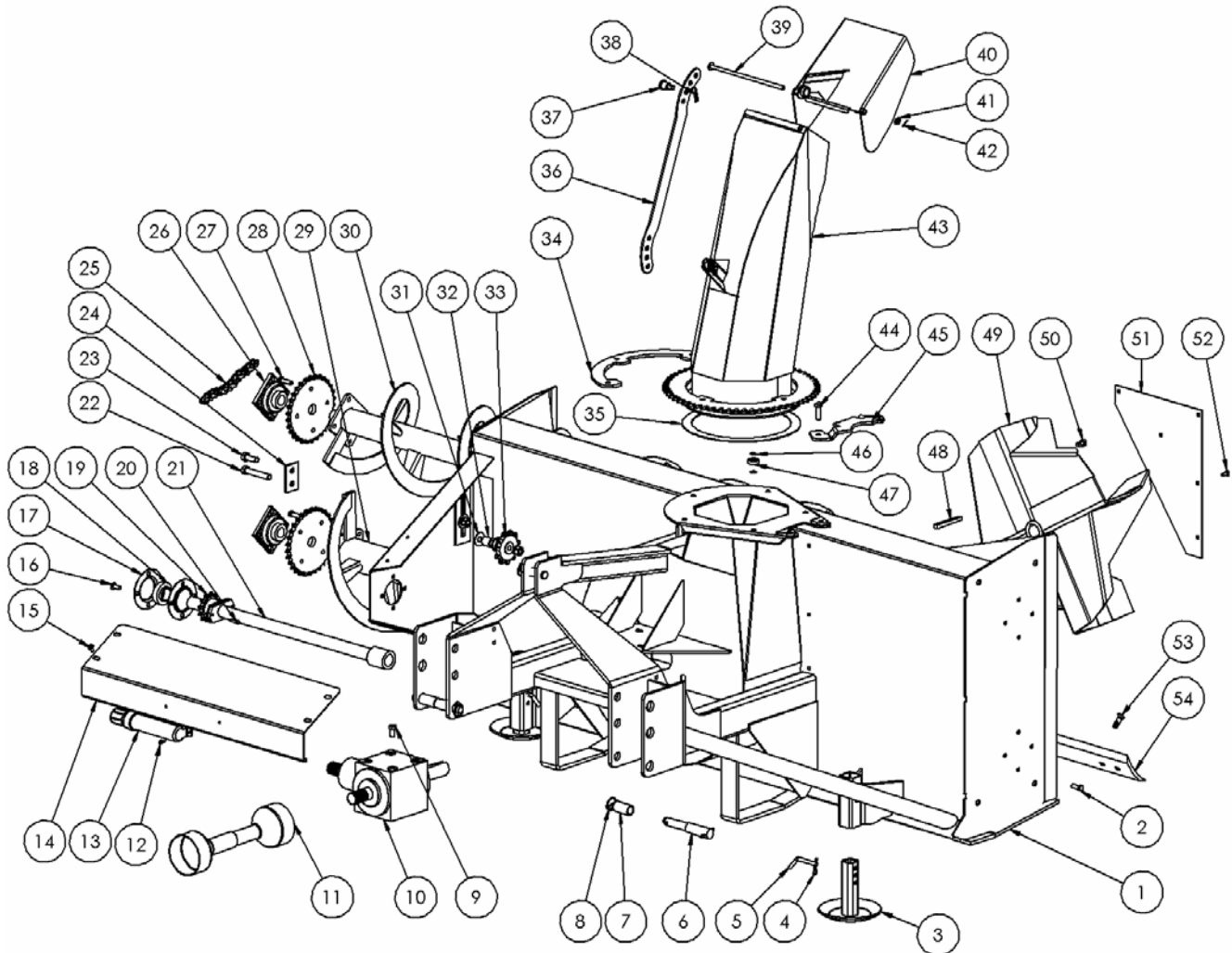

Item #	97D Part #	108 Part #	Description	Qty
1	519-21684	519-21587	Main Body	1
2	OL	OL	Bolt 1/2x1 1/2 c/w lw, n	16
3	519-21592	519-21592	Skid Shoe	2
4	OL	OL	Hair Pin 1/8"	2
5	OL	OL	Bent Pin 1/2"	2
6	519-21838	519-21838	Hitch Pin	2
7	519-1083097	519-1083092	Bushing	2
8	OL	OL	Lynch Pin	2
9	OL	OL	Bolt 5/8x1 1/2 c/w lw	8
10	519-1081186	519-1081186	Gearbox	1
11	519-1081187	519-1081187	PTO Assembly for 540 RPM	1
	519-1081187175	519-1081187175	PTO Assembly for 540 RPM Heavy Duty	1
12	OL	OL	Flange Head Bolt 1/4x2/4 c/w Flange Nut	2
13	DJA7011	DJA7011	Manual Tube	1
14	519-971184D	519-1081055	Auger Drive Shield	1
15	OL	OL	Flange Head Bolt 3/8x3/4	4

Item #	97D Part #	108 Part #	Description	Qty
16	OL	OL	Carriage Bolt 1/2x1 1/4 c/w lw, n	4
17	519-1081174	519-1081174	Flangette	2
18	519-1081175	519-1081175	Bearing (insert only)	1
19	519-1083025	519-1083025	Shear Sprocket	1
20	OL	OL	Shearbolt 5/16x1 1/4 #2 c/w ln	2
21	519-971184D	519-1081184	Auger Drive Shaft	1
22	OL	OL	Bolt 3/4x4 1/2 c/w lw, n	1
23	OL	OL	Bolt 3/4x2 c/w lw, n	1
24	519-1081026	519-1081026	Clamp Plate	1
25	519-1082026	519-1082026	Auger Drive Cain #80x 102	1
26	519-1081169	519-1081169	Bearing Complete	4
27	OL	OL	Bolt 1/2x2 c/w lw, n	8
28	519-1081165	519-1081169	Auger Sprocket 80A30T	2
29	519-971164D	519-1081164	Bottom Auger	1
30	519-971167D	519-1081167	Top Auger	1
31	OL	OL	Flatwasher 3/4"	2
32	519-1081028	519-1081028	Idler Spacer	1
33	519-1082029	519-1082029	Idler Sprocket	1
34	10723	10723	3 Hole Chute Clamp	1
35	519-1081161	519-1081161	Anti Friction Ring	1
36	10701	10701	Deflector Adjuster Bar	1
37	21773	21773	Deflector Adjuster Pin	2
38	OL	OL	Hair Pin 5/32	2
39	31513	31513	Deflector Hinge Pin	1
40	10714	10714	Deflector	1
41	OL	OL	SAE 1/2" Washer	1
42	OL	OL	Cotter Pin 1/8x1	1
43	10712	10712	Chute	1
44	OL	OL	Bolt 5/8-18x2 c/w lw, n	5
45	10722	10722	2 Hole Chute Clamp	1
46	519-871702	519-871702	5/8 Wave Washer (thin)	10
47	519-870711	519-870711	Bearing 5/8"	5
48	519-1081162	519-1081162	Fan Key 1/2sq x5 1/2	1
49	34568	34568	Fan	1
50	OL	OL	Bolt 5/8x1 1/2 c/w lw	1
51	519-20900	519-20900	Fan Plate	1
52	OL	OL	Carriage Bolt 3/8x1 c/w ln	5
53	OL x 9	OL x 10	Plow Bolt 5/8x2 c/w n	
54	783-100-804	783-100-904	Cutting Edge	1

**Note:**

OL - Obtain Locally | fw - Flatwasher | In - Locknut  
c/w - complete with | lw - Lockwasher | n - Nut

## Chute Stop

The Chute Stop is standard on all Meteor Snowblowers.

It prevents the chute from being rotated straight back to the operator.

It prevents the Hydraulic hoses (*if used*) from getting wound around the chute.

On the smaller blowers with electric deflector actuator the Chute Stop prevents the wires from getting wound up.

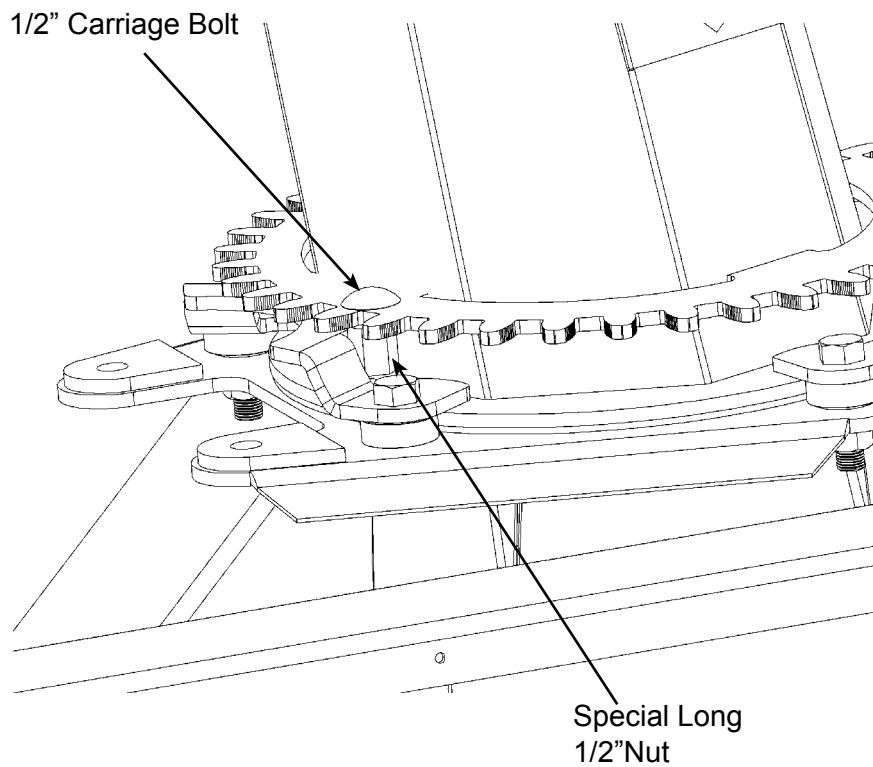

## Meteor Hydraulic Chute Rotator Parts

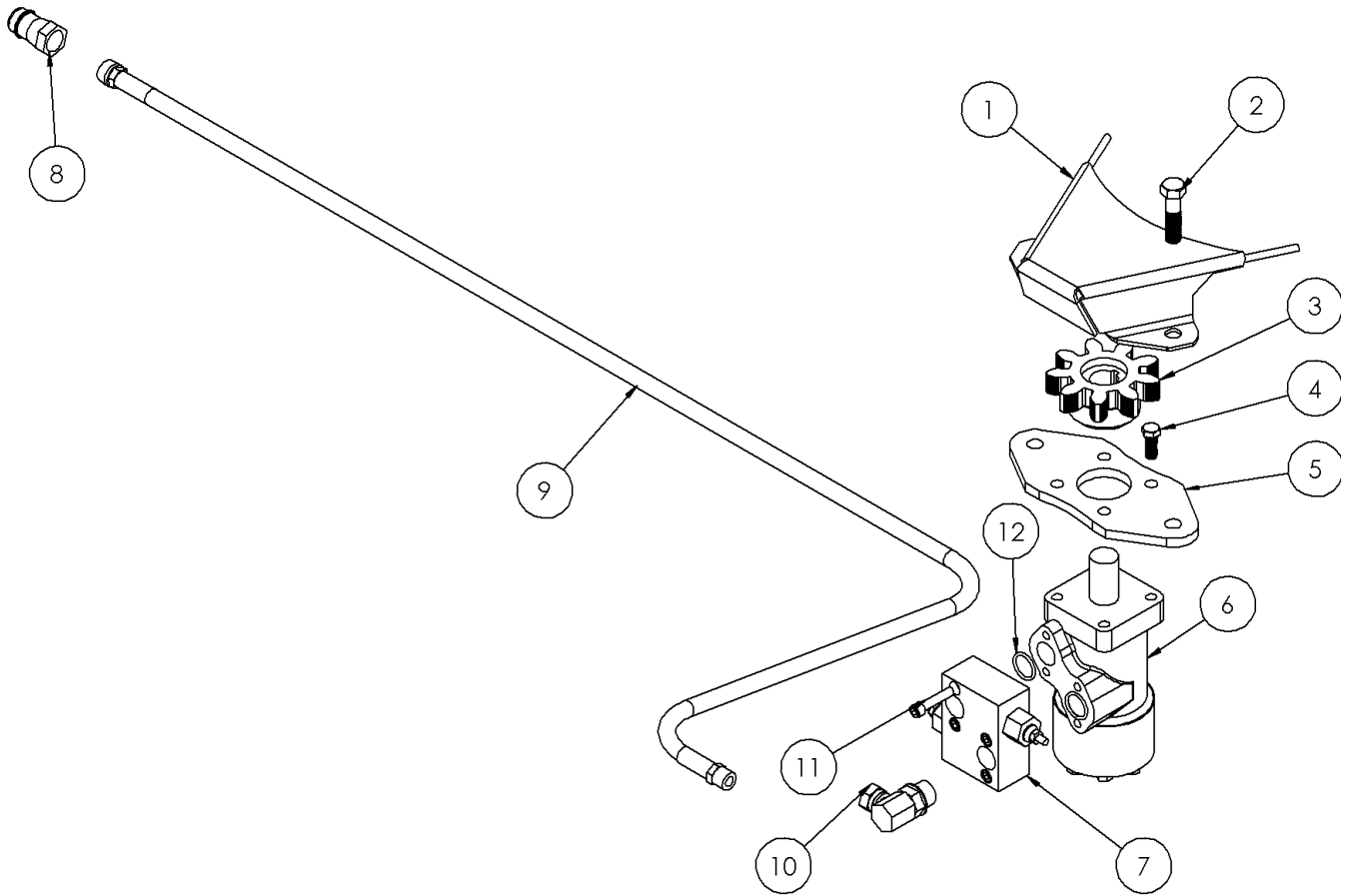

Item #	Part #	Description	Qty
1	23931	Shield	1
2	Bolt 1/2-20x2 c/w lw, n	OL*	2
3	519-511706	Small Gear	1
4	Bolt 3/8x1 c/w lw	OL*	4
5	519-511703	Motor Bracket	1
6	519-511704	Motor	1
7	519-511705	Crossover Relief Valve	1
8	S71-4	Tractor Adapter	2
9	23895	Hydraulic Hose	2
10	519-9515-10-6	Hydraulic Elbow	2
11	Socket Head Cap Screw 5/16x1 1/2	OL*	4
12	(O Ring 3/32x.75id	OL	2

**Note\***

**OL -- Obtain Locally**

### Comer T80 540 RPM PTO

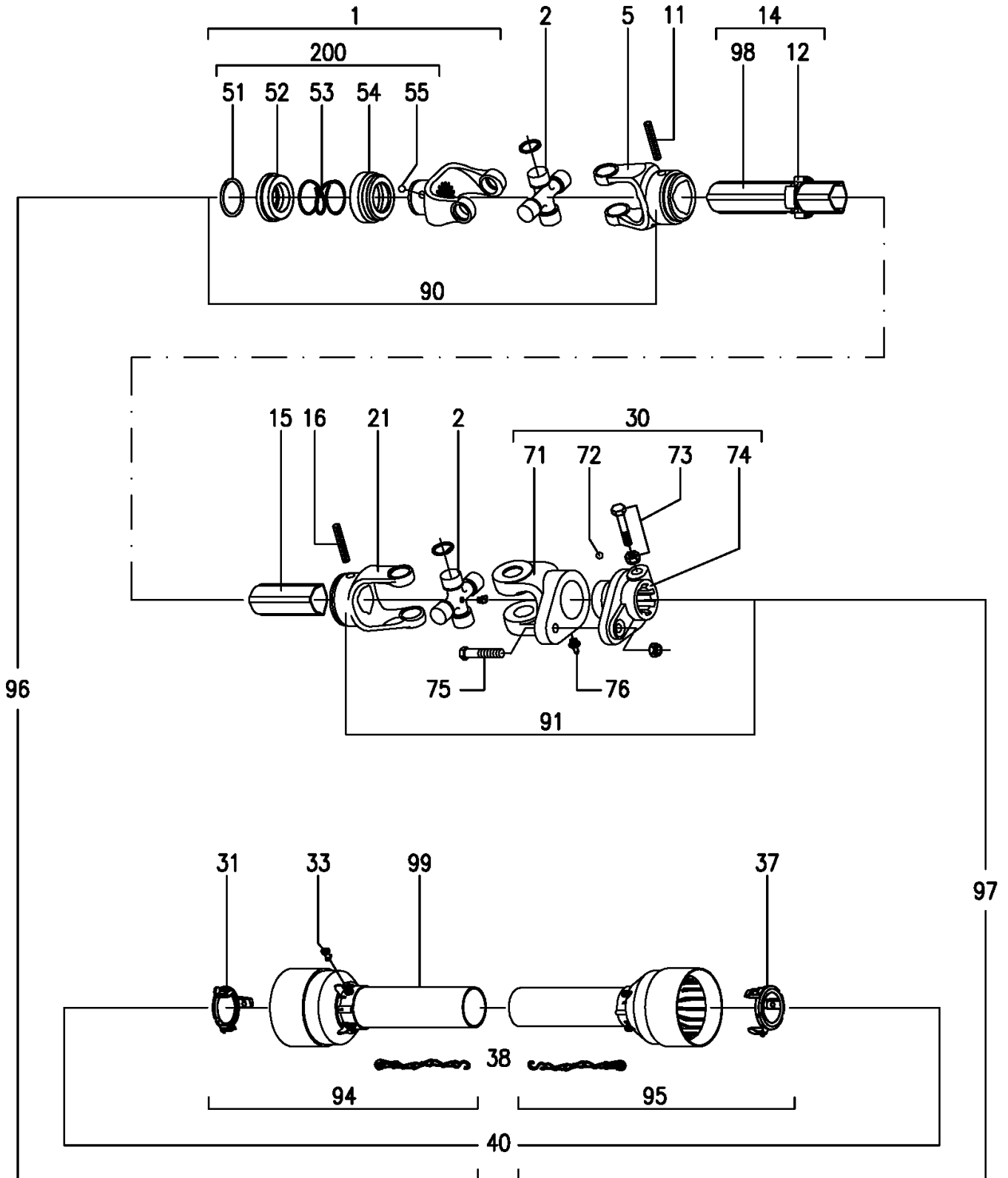

**Note:**

This PTO has 1 3/8 - 6 tooth yoke on one end and 1 3/4 - 20 tooth yoke on other end  
 Cross Bearing is 35mm or approx 1 3/8" dia

### Comer T80 540 RPM PTO

Item #	Description	Part#	Req
1	Complete Collar Yoke 1 3/8 - 6 T	141.028.423	1
2	Cross Journal Set 35x106.5	180.018.130	2
5	Outer Yoke	151.018.133	1
11	Roll Pin for outer Yoke	190.000.243	1
12	Bushing with Grease Fitting	180.018.210	1
14	Complete Outer Tube	152.198.174.0720	1
15	Inner Tube	159.190.026	1
16	Roll Pin for Inner Tube	190.000.271	1
21	Inner Yoke	151.018.134	1
30	Complete Shear Yoke	143.280.018	1
31	Guard Retaining Collar - Outer Tube	180.019.121	1
33	Special Plastic Bolt	190.000.019	6
37	Guard Retaining Collar - Inner Tube	180.019.122	1
38	Safety Chain	180.016.025	2
40	Complete Shield with Instruction Manual	142.286.017.7820	1
51	Outer Circlip	190.000.451	1
52	Sliding Sleeve Collar	151.016.486	1
53	Spring	180.116.487	1
54	Fixed Sleeve	180.016.483	1
55	Ball 1/2" dia	190.000.078	3
56	Yoke	151.018.423	1
71	Yoke for hub	151-018.023	1
72	Ball 5/16" dia	190.000.023	24
73	Bolt and Nut M12x1.25x75	165.000.598	2
74	Hub 1 3/4-20 T	151.018.162	1
75	Bolt and Nut M12x65 cl8.8	165.000.512	1
76	Grease Fitting M10x1	190.000.021	1
90	U Joint for Outer Tube	121.028.784.10	1
91	U Joint for Inner Tube	121.028.646.10	1
94	Half Female Guard	142.281.147.7820	1
95	Half Male Guard	142.281.256.7820	1
96	Half Female Shaft with Guard	123.380.210.10	1
97	Half Male Shaft with Guard	123.280.432.10	1
98	"Danger" label for Outer Shaft	190.000.216	1
99	"Danger" Label for Outer Guard Tube	190.000.215	1
100	Instruction Manual	190.000.371	1

**Note:**

This PTO has 1 3/8 - 6 tooth yoke on one end and 1 3/4 - 20 tooth yoke on other end  
Cross Bearing is 35mm or approx 1 3/8" dia

# Comer T90 540 RPM PTO

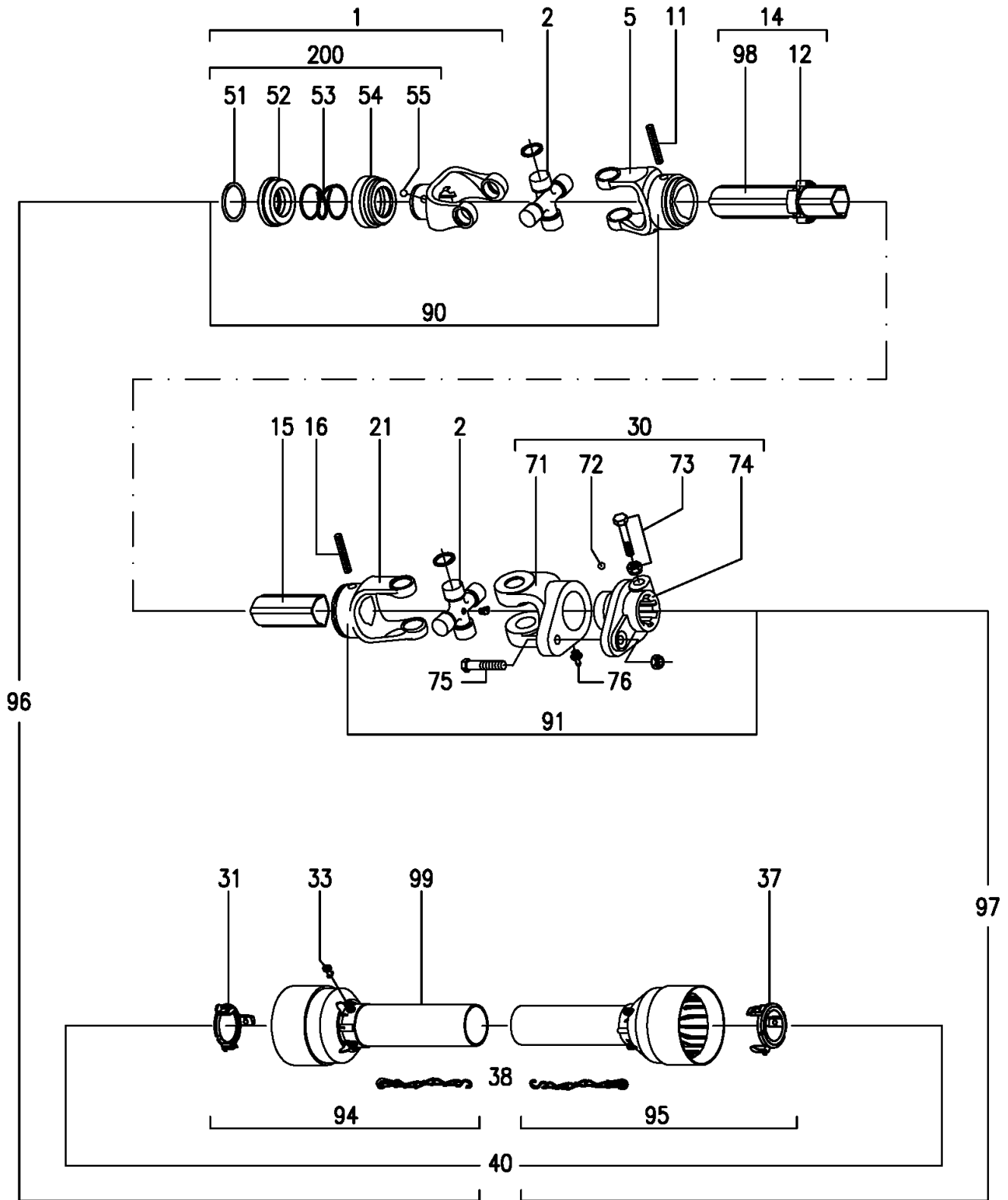

**Note:**

This PTO has 1 3/8 - 6 tooth yoke on one end and 1 3/4 - 20 tooth yoke on other end  
 Cross Bearing is 41mm or approx 1 5/8" dia



### Comer T90 540 RPM PTO

Item #	Description	Part#	Req
1	Complete Collar Yoke 1 3/8 - 6T	141.025.319	1
2	Cross Journal Set 41x108	180.019.130	2
5	Outer Yoke	151.019.127	1
11	Roll Pin for Outer Yoke	190.000.243	1
12	Bushing with Grease Fitting	180.018.210	1
14	Complete Outer Tube	152.198.520.0720	1
15	Inner Tube	153.190.507	1
16	Roll Pin for Inner Tube	190.000.243	1
21	Inner Yoke	151.019.128	1
30	Complete Shear Yoke 1 3/4-20T	143.290.005	1
31	Guard Retaining Collar for Outer Tube	180.019.121	1
33	Special Plastic Bolt	190.000.019	6
37	Guard Retaining Collar for Inner Tube	180.019.122	1
38	Safety Chain	180.016.025	2
40	Complete Shield with Instruction Manual	142.290.225.7920	1
51	Outer Circlip	190.000.451	1
52	Sliding Sleeve Collar	151.016.486	1
53	Spring	180.016.487	1
54	Fixed Sleeve Collar	180.016.483	1
55	Ball 1/2" dia	190.000.078	3
71	Yoke for Hub	151.019.136	1
72	Ball 5/6" dia	190.000.023	24
73	Bolt and Nut M16x2x80	165.000.576	2
74	Hub 1 3/4 - 20T	151.019.139	1
75	Bolt and Nut M12x65 cl8.8	165.000.512	1
76	Grease Fitting M10x1	190.000.021	1
90	U Joint Outer Tube	121.029.572.10	1
91	U Joint Inner Tube	121.029.523.10	1
94	Half Female Guard	142.291.105.7920	1
95	Half Male Guard	142.291.205.7920	1
96	Half Female Shaft with Guard	123.390.039.10	1
97	Half Male shaft with Guard	123.290.304.10	1
98	"Danger" Label for Outer Tube	190.000.216	1
99	"Danger" Label for OUtter Guard Tube	190.000.215	1
100	Instruction Manual	190.000.371	1
200	Kit Collar 1 3/8"	165.000.628	1

**Note:**

This PTO has 1 3/8 - 6 tooth yoke on one end and 1 3/4 - 20 tooth yoke on other end  
Cross Bearing is 41mm or approx 1 5/8" dia

1000 RPM GearBox Parts

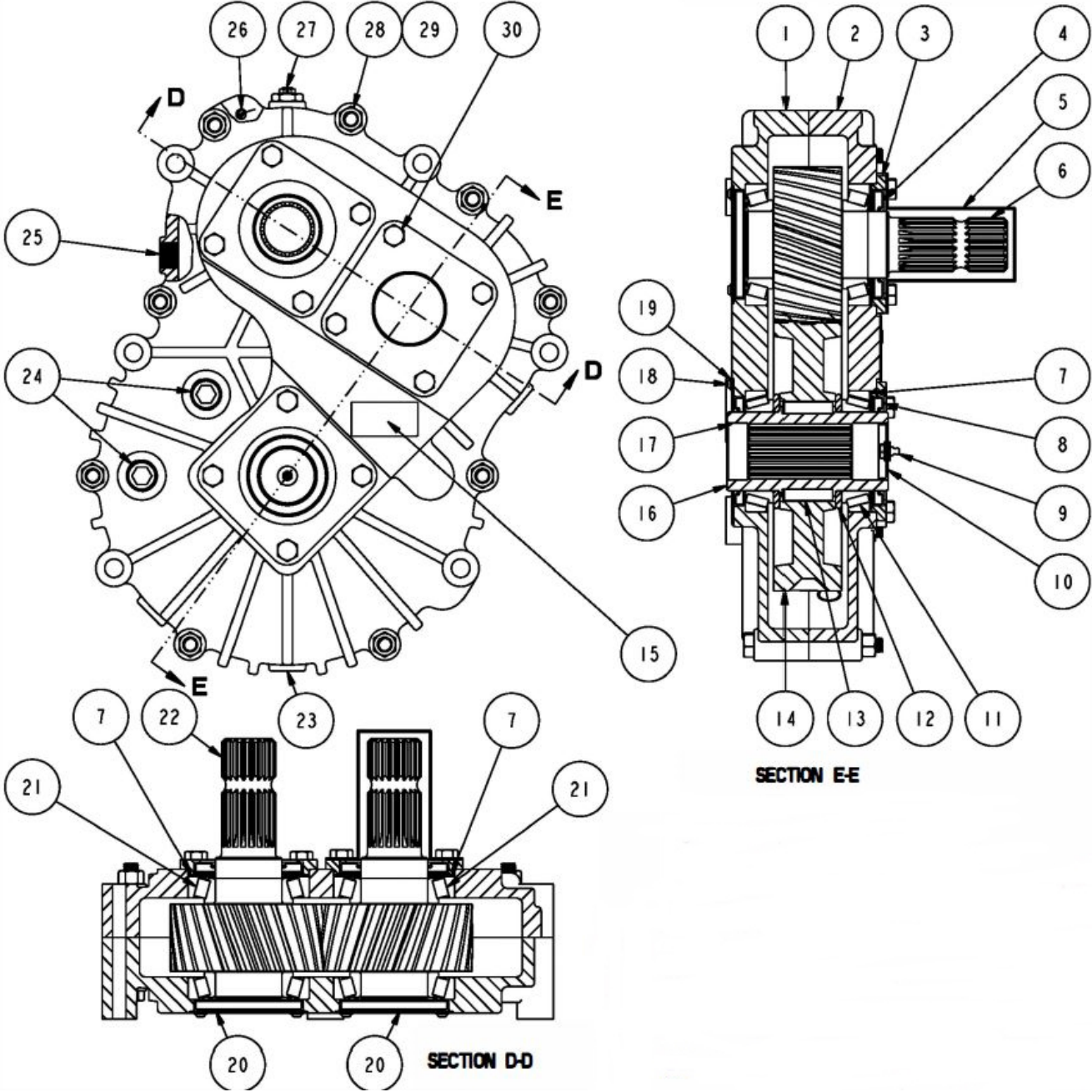

## 1000 RPM GearBox Parts

Item #	Part #	Description	Qty
1	52681	Lower Housing 1.84:1	1
2	52682	Upper Housing 1.84:1	1
3	52683	Hollow Cover	3
4	52684	Seal [55x90x8]	2
5	52685	Protective Guard	1
6	52686	Middle Gear Shaft 1-3/4Z20 1.84:1	1
7	52687	Shims [Ø90 x Ø99.8]	
8	52688	Seal [65x90x8]	2
9	52689	Grease Fitting [M6x1.0]	1
10	52690	End Cap [47x8]	1
11	52691	Bearing 32013	2
12	52692	Spacer [65x94x5]	2
13	52693	Round End Key [16x10x40]	2
14	52694	Output Gear 1.84:1	1
15		Name plate	1
16	52695	Output Shaft 1-3/4Z20	1
17	52696	Seal Retainer W/Hole	3
18	OL	Button Head Screw [M4x0.7x8mm]	12
19	OL	Washer [M4]	12
20	52697	End Cap [90x8]	2
21	52698	Bearing 30211	4
22	52699	Input Gear Shaft 1-3/4Z20 1.84:1	1
23	52700	Magnetic Plug 1/2-14 NPT	1
24	OL	Plug 3/4-14 NPT	2
25	OL	Plug 1/2-14 NPT	3
26	52701	Dowel Pin [8x20]	2
27	52702	Pressure Vent 5 PSI 1/2-14 NPT	1
28	OL	Bolt [M12x1.75x105mm]	9
29	OL	Nut [M12x1.75]	9
30	OL	Bolt [M10x1.5x20mm]	12

# 1000 RPM PTO

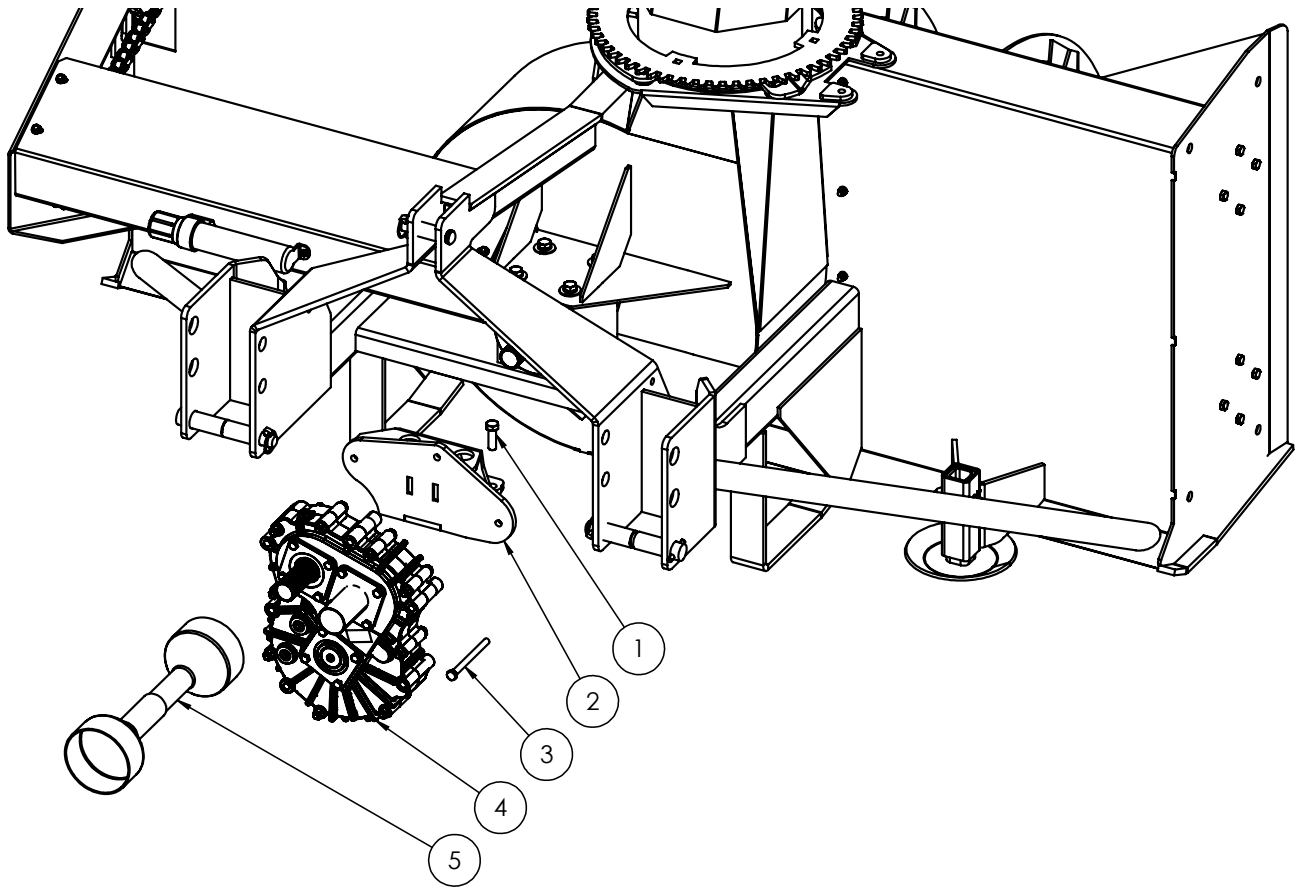

Item #	Part #	Description	Qty
1	OL	Bolt 5/8 x 2 c/w lw	4
2	52106	Gearbox Mount	1
3	OL	Bolt 1/2 x 6 c/w ln	3
4	52680	Reduction Gearbox	1
5	519-1081187F	PTO Assy 1 3/8 Ø	1
	519-1081187F175	PTO Assy 1 3/4 Ø	1

Comer T80 1000 RPM PTO

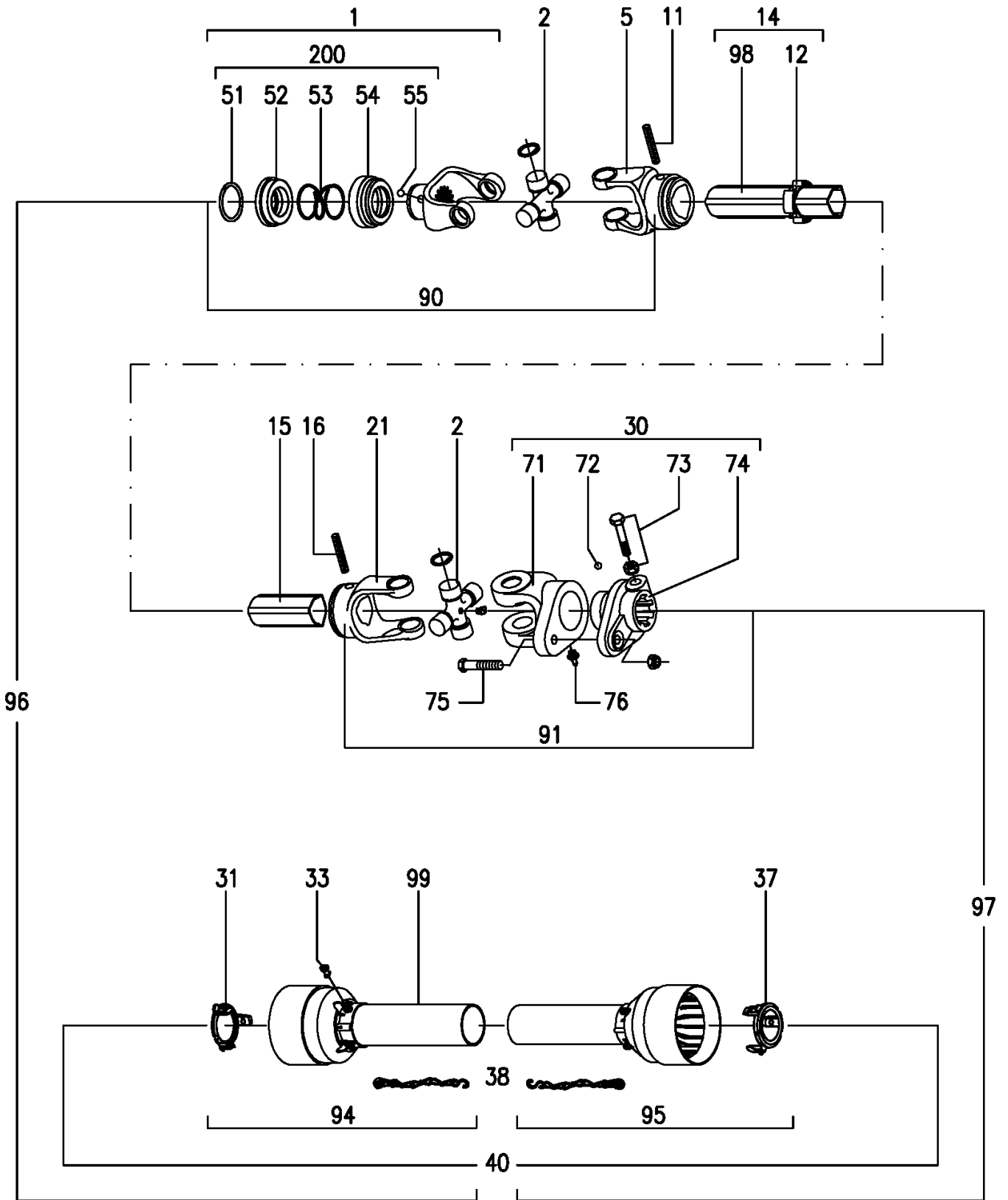

**Note:**

This PTO has 1 3/8 21 tooth yoke on one end and 1 3/4 - 20 tooth yoke on other end  
 Cross Bearing is 35mm or approx 1 3/8" dia

### Comer T80 1000 RPM PTO

Item #	Description	Part#	Req
1	Complete Collar Yoke 1 3/8"-21T	141.028.426	1
2	Cross Journal Set	108.018.130	2
5	Outer Yoke	151.018.133	1
11	Roll pin for outer tube	190.000.243	1
12	Bush with grease fitting	180.018.210	1
14	Complete outer tube	152.198.171.0720	1
15	Inner tube	159.190.025	1
16	Roll pin fot inner tube	190.000.271	1
21	Inner yoke	151.018.134	1
30	Complete shear bolt B35 yoke 1 3/4"20T	143.280.018	1
31	Guard retaining collar/outer tube	180.019.121	1
33	Special Plastic Bolt	190.000.019	6
37	Guard retaining collar/inner tube	180.019.122	1
38	Safety chain	180.016.636	2
40	Complete shield with instruction manual	142.286.028.7820	1
51	Outer circlip	190.000.451	1
52	Sliding sleeve collar	151.016.486	1
53	Spring	180.016.487	1
54	Fixed sleeve	180.016.483	1
55	Ball 1/2" dia	190.000.078	3
71	Yoke for hub B35	151.018.023	1
72	Ball 5/16 dia	190.000.023	24
73	Bolt/Nut M16x2x80	165.000.576	2
74	Hub B35 (57xM12) 1 3/4"	151.018.162	1
75	Bolt/Nut M12x1.5x65 cl8.8	165.000.512	1
76	Grease fitting M10x1	190.000.021	1
90	U Joint for outer tube	121.028.786.10	1
91	U Joint for inner tube	121.028.646.10	1
94	Half female guard	142.281.152.7820	1
95	Half male guard	142.281.261.7820	1
96	Half female shaft with guard	123.380.226.10	1
97	Half male shaft with guard	123.280.380.10	1
98	Danger label for outer tube	190.000.216	1
99	Danger label for inner tube	190.000.215	1
100	Instruction manual	190.000.371	1
200	Collar Kit	165.000.628	1

**Note:**

This PTO has 1 3/8 21 tooth yoke on one end and 1 3/4 - 20 tooth yoke on other end  
Cross Bearing is 35mm or approx 1 3/8" dia

### T279-A Gearbox

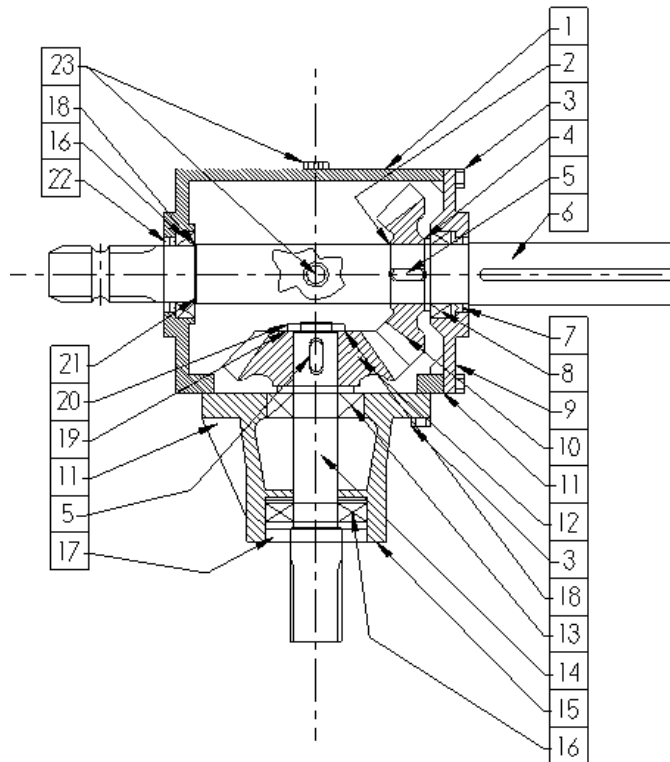

Item #	Description	Part #	Req'd
1	Casing T4	519-0.279.0300.00	1
2	Snap Ring	519-8.5.1.00533	1
3	Bolt M10 x 32	519-8.1.1.00501	16
4	Shim 70.3	519-0.712.7500.00	1
5	Parallel Key	519-8.4.1.00978	2
6	Shaft	519-0.279.3010.00	1
7	Oil Seal 50x72x8	519-8.7.1.01097	1
8	Bearing 30210	519-8.0.9.00469	1
9	Cover	519-0.279.1300.00	1
10	Gear Z21 M7.14	519-0.279.6000.00	1
11	Gasket	519-0.248.7200.00	1
12	Gear Z21 M7.14	519-0.279.5000.00	1
13	Bearing 30209	519-8.0.9.00125	2
14	Shaft 1 3/4" Z20	519-0.279.2000.00	1
15	Extension AC	519-0.279.1301.00	1
16	Bearing 30209	519-8.0.9.00143	1
17	Oil Seal 52x85x10	519-8.7.3.01096	1
18	Shim 65.3	519-0.252.7500.00	2
19	Spring Washer	519-8.3.8.00065	1
20	Locknut M40x1.5	519-8.2.5.00064	1
21	Shim 45.3 2.5	519-0.252.7525.00	1
22	Double Lip Seal	519-8.7.1.00981	1
23	Plug 3/8" Gas	519-8.6.6.00201	4
24	Shim 40.3x1.0	519-0.244.7510.00	1



## PTO Installation Instructions for Snowblower

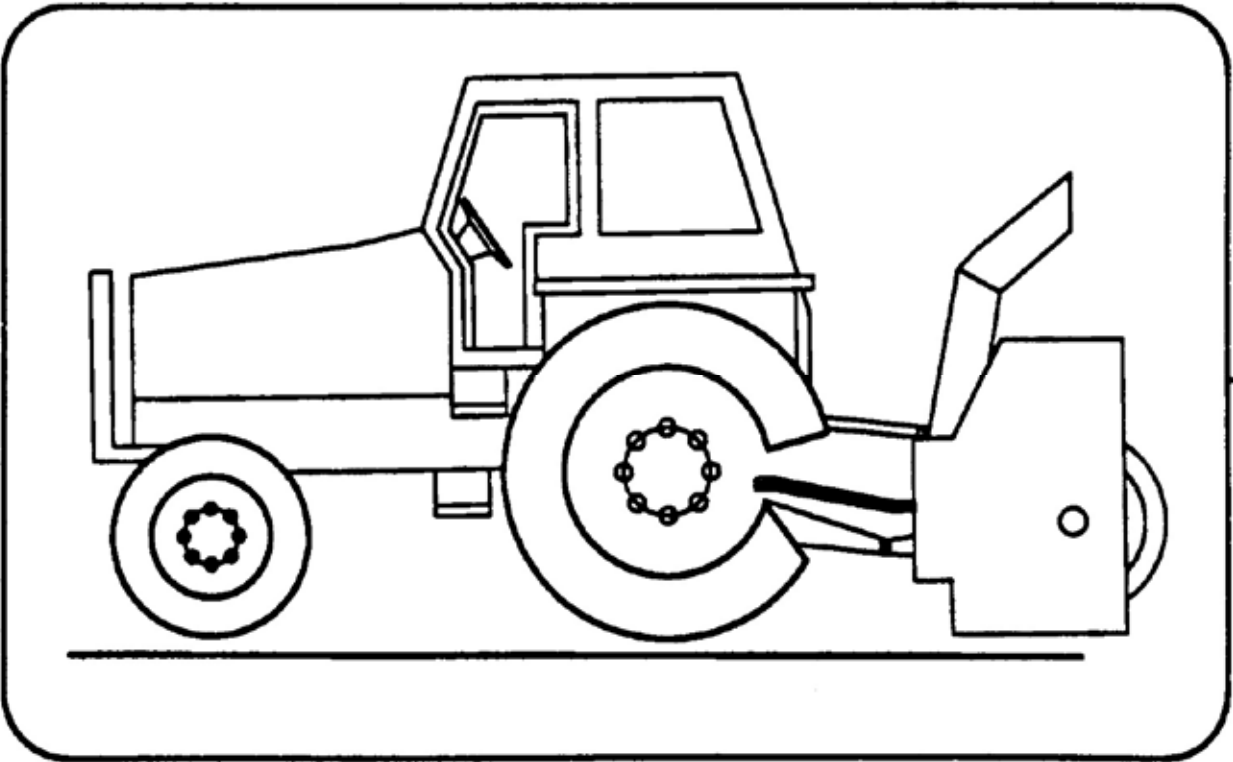



**PTO Installation Instructions for Snowblower  
For Better PTO Shaft and Gearbox Operation**

A proper initial installation will give you years of satisfactory service on your equipment. Please read carefully, following instructions which have been specially made to help you and make you satisfied with your purchase.

**Warning!** Unfortunately, snowblowers will be faced with forgotten or hidden objects under the snow, such as: chain, tires, stones, pieces of wood, etc. In spite of all our efforts, machines are not built to resist all those conditions.

**Danger: Too big tractors**

It is dangerous to use a tractor that is too big or too powerful. The tractor will always be able to overload the blower, even if the machine is already at maximum capacity. Tractor being very high, too large angles at PTO universal joints will result, and the life of the universal joints will be shortened dramatically.

**P T O Shaft angles**

PTO shafts are made to transmit power with angle at universal joints. However these angles should be kept to a minimum. Larger angles shorten the life of PTO. Take for example a snowblower sold for a tractor horse-power of 60-75 HP which would be attached to a 60HP tractor operating at maximum capacity of (60HP continuous).

<b>HP</b>	<b>PTO angles</b>	<b>Estimated life in hours</b>
60@540 RPM	5°	450 hours
	10°	195 hours
	15°	90 hours
	20°	40 hours
	25°	20 hours

**How to determine PTO angle**

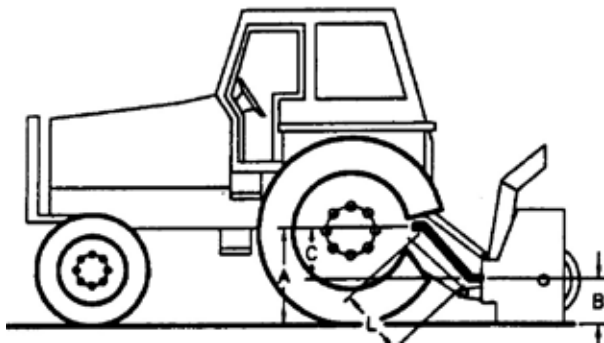

- A =PTO height at tractor
- B= PTO height at blower
- C= A-B
- L = Cross center distance in working position

- 1) Lower blower on ground
- 2) Measure A,B and L
- 3) Subtract B from A (A-B=C)
- 4) Divide L by C (L/C=F)
- 5) Compare F Factor in the table below to find PTO angle. (Interpolate if necessary)

<b>F Factor</b>	<b>Angle</b>
6	10°
3.75	15°
2.75	20°
2.15	25°
1.75	30°

Previous examples clearly demonstrate that universal joint angle is directly related with life of PTO. In order to reduce angle, it is necessary to increase the distance between snowblower and tractor.

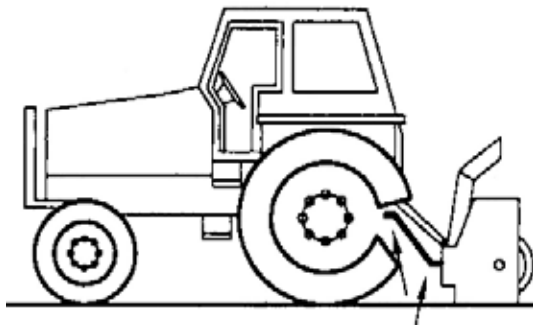

**Too Large Angles at PTO Joints  
To Avoid**

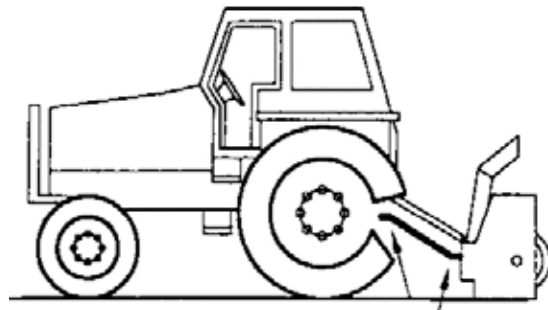

**Reasonable Angles at PTO Joints  
Acceptable**

If it is impossible to increase the distance between snowblower and tractor, in order to maintain a reasonable angle at the PTO, it is recommended to use a larger size PTO that is a greater capacity PTO. (please refer to your dealer for more details).

For snowblowers of 100HP, an additional gearbox is also available that can be mounted on the existing snowblower gearbox, which increases the input shaft height, reducing the angle at PTO joints. This Gearbox has an input speed of 1000RPM which greatly increases PTO capacity.

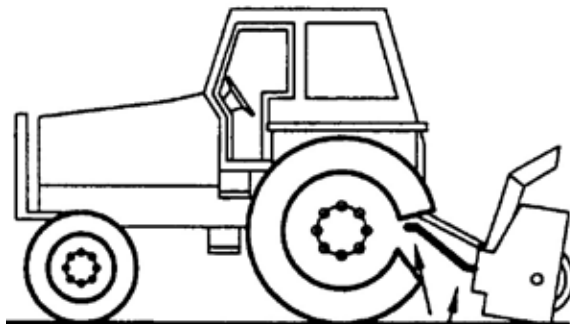

**Non-Equal Angles at PTO Joints  
To Avoid**

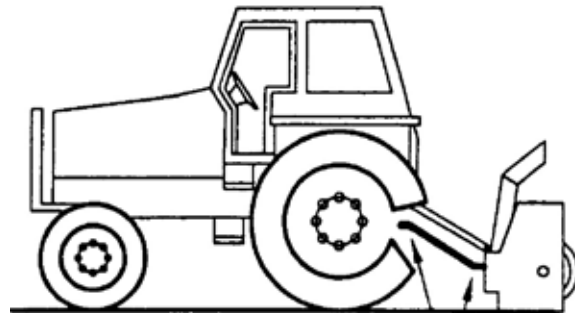

**Equal Angles At PTO Joints  
Recommended**

### Angles at each end of PTO

A popular habit is to change snowblower angle in order to obtain a better scraping effect. This practice can become harmful to the PTO if the angle is unequal at each end, There will be fan speed variation (as the fan speed up and slow down twice per revolution) as well as a drastic increase of loading on the cross and bearings. **To avoid** it is recommended to keep tractor PTO and snowblower input shaft always parallel.

## **Shear Bolts**

Shear bolts are built to break under shock loads on the fan or auger. However under certain circumstances this security is not adequate. Example: a sudden high impact shock on the fan may, in some cases break the fan shaft without breaking the shear bolt.

If the shear bolt breaks, make sure to always replace it with the same grade of bolt (grade 5 for PTO series **20-40-50-60**, and grade 8 for PTO series **80**) it is necessary to always maintain this bolt very tight in order to keep the efficiency of the shearing mechanism.

**Warning:** The gearbox shafts are made with special alloy steel. However they are case hardened to increase capacity to shock load. These shafts cannot be broken under normal loads. However undesirable objects may enter the fan and either bend or break the gearbox shaft. It is understood that the gearbox cannot be built to resist every possible overload and consequently, gearbox fan shafts will not be replaced under warranty. Therefore the user of the snowblower must be very careful.

## **Maximum length of PTO shaft**

**Warning:** Telescopic tubes of PTO should overlap a minimum length to meet ideal conditions for transmitting power.

Following table could be used as a guide to find maximum permissible length of PTO.

PTO Description	Over-all length Closed	Over-all length Opened Max	Telescopic tube overlap
<b>T20-056P</b>	<b>29 3/4"</b>	<b>41"</b>	<b>5"</b>
<b>T40-056P</b>	<b>30 1/2"</b>	<b>40 1/2"</b>	<b>6"</b>
<b>T50-071P</b>	<b>36 1/2"</b>	<b>51 1/4"</b>	<b>7"</b>
<b>T60-071P</b>	<b>37 3/4"</b>	<b>51 1/4"</b>	<b>7"</b>
<b>T80-066P</b>	<b>36"</b>	<b>47 1/4"</b>	<b>7"</b>
<b>T80-076P</b>	<b>40 1/2"</b>	<b>53"</b>	<b>8"</b>
<b>T90-071P</b>	<b>39"</b>	<b>51"</b>	<b>8"</b>





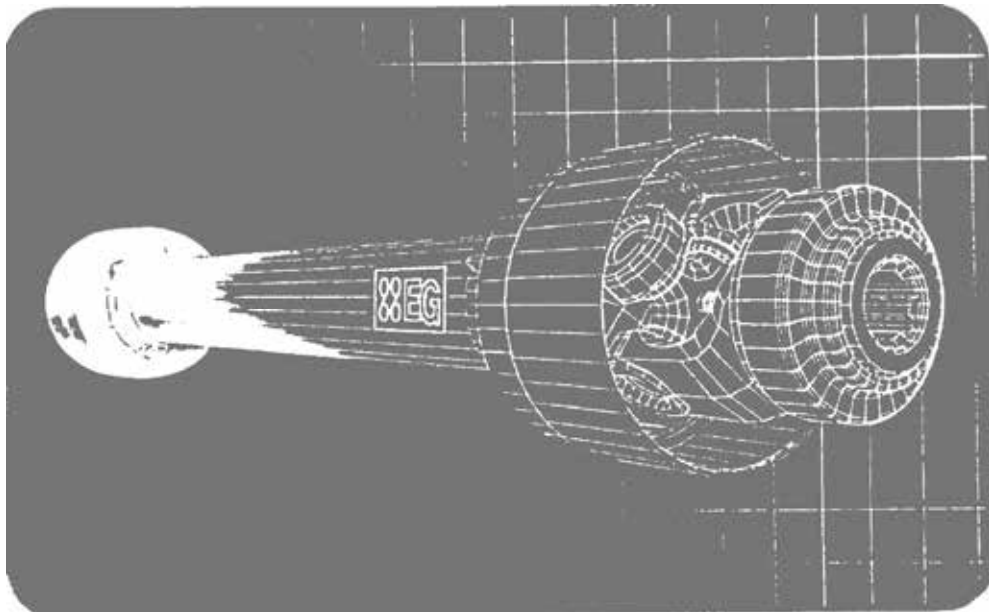

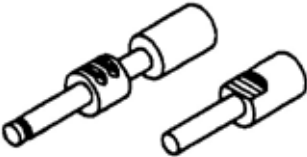



## Effective PTO Drive Shaft Maintenance





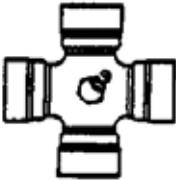

	<b>Avoidable Damage</b>	<b>Possible Causes</b>	<b>Corrective Actions</b>
<p>Quick-disconnect yoke</p> 	<p>Quick-disconnect pin tight or completely seized Quick-disconnect pin damaged (broken or bent) Quick-disconnect pin damaged in locking position</p> 	<p>Quick-disconnect pin dirty (insufficient maintenance) Quick-disconnect pin defective (forced into place, incorrect handling). Excessive shaft length Axial load too high</p>	<p>Clean, oil and follow service instruction Replace Quick-disconnect pin Shorten shaft length (cut both telescopic tubes as well as shield, remove burrs) Replace Quick-disconnect pin Clean and grease telescopic tubes. Replace both tubes if necessary</p>

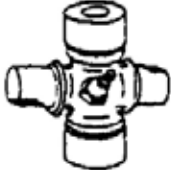
Note: newer PTO shafts may have a locking collar. (Damages Causes and corrective actions will still be similar.



	<b>Avoidable Damage</b>	<b>Possible Causes</b>	<b>Corrective Actions</b>
<p>Yoke</p>  	<p>Deformed Yoke</p>  	<p>Excessive shaft length Axial load too high Excessive working angle and torque</p>	<p>Shorten shaft length (cut both telescopic tubes as well as shield, remove burrs) Replace defective yokes Clean and grease telescopic tubes. Replace both tubes if necessary Replace defective yokes Verify compatibility between shaft and working conditions (torque vs. angle) Disengage tractor PTO during lifting or lowering the implement. Change to a larger PTO size</p>
	<p>Distorted Yoke</p> 	<p>Overload caused by high starting and peak torque</p>	<p>Engage PTO more carefully Use appropriate safety device Replace defective yoke</p>
	<p>Worn or pounded Yoke</p> 	<p>Excessive working angle</p>	<p>Avoid excessive angle Replace defective yokes</p>

	<b>Avoidable Damages</b>	<b>Possible Causes</b>	<b>Corrective Actions</b>
<p>Cross Kit</p> 	<p>Cross Arms broken</p> 	<p>Extreme torque peak or shock load</p> <p>Axial loads too large</p>	<p>Use appropriate safety device</p> <p>Change to a larger PTO size</p> <p>Shorten PTO shaft</p> <p>Replace defective cross bearings</p>
	<p>Bearing caps turning in their cross journal</p> <p>Overheated bearing caps</p>	<p>Excessive continuous torque and/or excessive working angle</p> <p>Inadequate greasing</p>	<p>Verify compatibility between shaft and working conditions</p> <p>Carefully follow greasing instructions</p> <p>Replace defective cross bearings</p>
	<p>Accelerated wear of cross kit</p> 	<p>Excessive continuous torque and/or excessive working angle</p> <p>Inadequate greasing</p>	<p>Verify compatibility between shaft and working conditions</p> <p>Carefully follow greasing instructions</p> <p>Replace defective cross bearings</p>

**Note: Cross bearings must be greased every 8 working hours**

	<b>Avoidable Damages</b>	<b>Possible Causes</b>	<b>Corrective Actions</b>
<p>Telescopic tube</p> 	<p>Telescopic tube failure or twisting</p> 	<p>Excessive torque or shock load</p> <p>Short tube engagement (overlap)</p>	<p>Use appropriate safety device</p> <p>Change to a larger PTO size</p> <p>Replace the PTO drive shaft with one of adequate length</p> <p>Replace defective tubes</p>
	<p>Accelerated wear of telescopic tubes</p> 	<p>Accelerated wear of telescopic tubes</p> 	<p>Extreme load when sliding</p> <p>Short tube engagement</p> <p>Inadequate greasing</p> <p>Conditions (sand etc)</p>

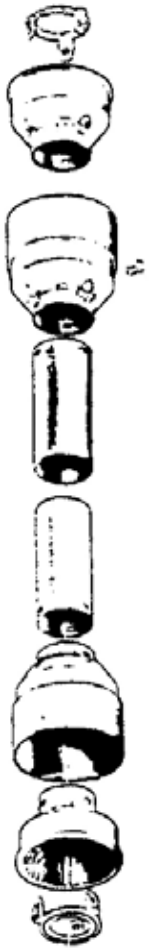
**Note: Telescopic tubes must be cleaned and greased every 16 working hours**

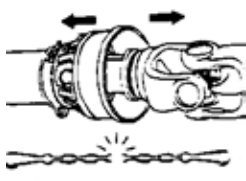
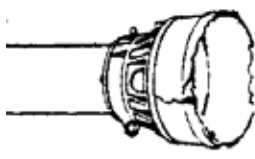
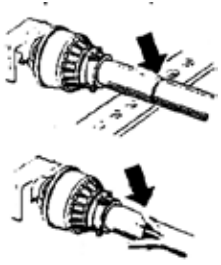
	<b>Avoidable Damages</b>	<b>Possible Causes</b>	<b>Corrective Actions</b>
	Excessive wear of shield bearings 	Insufficient lubrication Incorrect chain mounting Shield interfering with implement	Follow lubrication instructions Mount chain to allow maximum angularity Avoid shield contact with machine or tractor Replace shield bearings
	Chain failure 	Shield interfering with implement Incorrect chain mounting	Avoid shield contact with machine or tractor Mount chain to allow for maximum angularity Replace defective parts
	Guard cone damaged 	Guard cone in contact with implement or tractor Excessive angularity	Eliminate interference between guard cone and any part of implement or tractor Avoid excessive angles Replace damaged guard cone
	Guard tubes damaged (deformed and split at one side) 	Guards are in contact with tractor or implement Guard tube overlap too short or no overlap with PTO tube extended	Eliminate interference between guard cone and any part of implement or tractor Replace damaged tubes Adjust guard tube length with longer tubes

**Note:** Shield bearing must be greased every 8 working hours

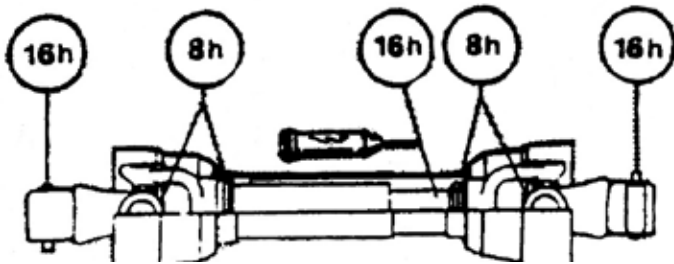

**Bolt Torque**  
As used on this equipment

Bolt torque table shown below gives torque values for the various bolts used.  
This chart is for non-lubricated threads.  
Replace with the same strength bolt.

Torque Specifications. Torque values are identified by their head markings

Diameter	SAE 2		SAE 5		SAE 8	
"A"	Lb-ft	N.m	Lb-ft	N.m	Lb-ft	N.m
1/4	6	(8)	9	(12)	12	(17)
5/16	10	(13)	19	(25)	27	(36)
3/8	20	(27)	33	(45)	45	(63)
7/16	30	(41)	53	(72)	75	(100)
1/2	45	(61)	80	(110)	115	(155)
5/8	95	(128)	160	(215)	220	(305)
3/4	165	(225)	290	(390)	400	(540)
1	225	(345)	630	(850)	970	(1320)

Allen head cap screws are similar to SAE 8 quality.

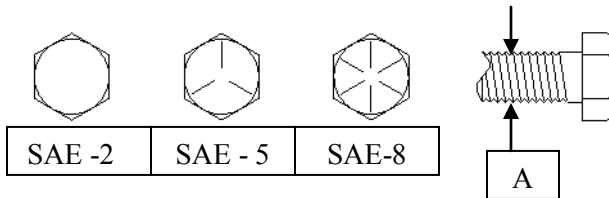

These torques are for a reference only. Not all these sizes and grades are necessarily used in this machine. Bolts that are used as a pivot or hinge have to be used with a locknut, therefore only tighten enough to secure the bolt and still allowing the part to rotate freely.



## 97D - 108 Meteor Snowblower

### Maintenance

- PTO Shearbolt – refer to PTO assembly
- Auger Shearbolts – 5/16 x 1 1/4” Gr #2
- Auger Drive Chain Tightener – tighten chain allowing 1/4” sag in the bottom span of chain (between drive and driven sprocket).

### Lubrication

- Gearbox- check oil level every **50** hours. Fill to oil level plug (middle of gearbox) with SAE 90 gear oil. SAE 80W90 gear oil may also be used.
- Auger and Shear Sprocket Bearing – grease sparingly every **50** hours. (By using too much grease you will push the seals off the bearing).
- PTO Shaft – grease every **10** hours. Pull apart and apply grease to the sliding members. Grease the yoke bearings at this time as well.
- Auger Chain – apply oil on a regular basis especially after using the snowblower.

### Storing the Meteor Snowblower in the off season

- At the end of the season lubricate the Bearings, PTO shaft and Auger chain before storing it.

### Notes

Part numbers – Abbreviations

O/L – obtain locally

N --- Nut

LW- Lockwasher

- All fasteners are Grade #2 unless otherwise specified.
- Customer supplies hydraulic cylinders.

### Notice:

To identify PTO shaft see Note at bottom of PTO pages







MK Martin Enterprise Inc.  
3950 Steffler Rd Elmira, ON, Canada N3B 2Z3

Tel: 519-664-2752  
Toll Free: 1-855-664-2752  
Fax: 519-664-3695  
E-mail: [sales@mkmartin.ca](mailto:sales@mkmartin.ca)  
[www.mkmartin.ca](http://www.mkmartin.ca)